





■ SUITABLE FOR

Liquids	neutral and non-neutral	
Air, gases and vapours	neutral and non-neutral	
Warm water		

■ EXAMPLES OF USE

For the protection of:

- domestic water supply systems
- commercial and industrial plants

against too high supply pressure.

Pressure reducers are used, if within a piping system despite of varying pressures on the inlet side a certain pressure must not be exceeded on the outlet side.

- potable water supply according to DIN 1988
- process water supply in industrial-and building technology
- snow-making equipment
- fire-fighting equipment and sprinkler systems
- shipbuilding industry and offshore plants



■ MATERIAL



■ SPECIFICATION



1/2" – 2"



– 10°C to + 95°C



Inlet pressure:
up to 40 bar
Outlet pressure:
0,5 to 15 bar
depending on version

■ APPROVALS

DIN-DVGW type examination

Type approval ACS

Type approval WRAS

Type approval SINTEF

TR ZU 032/2013 - TR ZU 010/2011

Requirements

DIN DVGW guidelines
DIN EN 1567
DIN 1988

DIN EN ISO 3822
PED 2014/68/EU

Classification society

Germanischer Lloyd
Lloyd's Register EMEA
American Bureau of Shipping
Bureau Veritas
Russian Maritime Register of Shipping

GL
LR EMEA
ABS
BV
RS

■ MATERIALS

Component	Material	DIN EN	ASME
Inlet body	Gunmetal	CC499K	CC499K
Outlet body	Gunmetal	CC499K	CC499K
Internal parts	Gunmetal	CC499K	CC499K
	Stainless Steel	1.4404	316 L
Spring	Spring steel with anti-rust protection	1.1200	ASTM A228
Strainer	Stainless Steel	1.4404	316 L

■ VALVE VERSION

m	with diaphragm	High-quality, heat-resistant moulded elastomere, fabric-reinforced diaphragm. Adjustment by means of non-rising spindle. Insert with balanced single seat valve made of gunmetal.
----------	----------------	---

Complete valve insert SP/HP (order code: 681 Insert-DN.-seal) available as replacement part can be exchanged without removing the valve.

Complete valve insert LP (order code: 681 LP Insert-DN.-seal) available as replacement part can be exchanged without removing the valve.

Built-in dirt trap made of stainless steel.

Mesh size:	DN 15 to DN 32	0,60 mm
	DN 40 and DN 50	0,75 mm

■ MEDIUM

GF	gaseous and liquid	for water, neutral and non-sticking liquids, compressed air and neutral gases; optionally with FPM elastomere seals for non-neutral media i.e. oils, fuels, oil-laden compressed air, etc.
-----------	--------------------	--

■ TYPE OF LIFTING MECHANISM

0	without lifting device
----------	------------------------

■ OUTLET PRESSURE RANGES

SP	Standard version	Inlet pressure: up to 40 bar	Outlet pressure: from 1 to 8 bar
HP	High-pressure version	Inlet pressure: up to 40 bar	Outlet pressure: from 5 to 15 bar
LP	Low-pressure version	Inlet pressure: up to 25 bar	Outlet pressure: from 0,5 to 2 bar

Fixed setting at a required outlet pressure against surcharge.

■ AVAILABLE NOMINAL DIAMETERS AND CONNECTION SIZES

Nominal diameter DN	15	20	25	32	40	50
Inlet	1/2" (15)	3/4" (20)	1" (25)	1 1/4" (32)	1 1/2" (40)	2" (50)
Outlet	1/2" (15)	3/4" (20)	1" (25)	1 1/4" (32)	1 1/2" (40)	2" (50)

■ TYPE OF CONNECTION INLET / OUTLET THREADED CONNECTIONS

BSP-Tm / BSP-Tm	Standard threaded connections	Male thread BSP-T / Male thread BSP-T	DIN EN 10226, ISO 7-1 / DIN EN 10226, ISO 7-1
f / f	Version with female thread available in sizes DN15, DN20 and DN25	Female thread BSP-P / Female thread BSP-P	DIN EN ISO 228-1 / DIN EN ISO 228-1

■ SEALS

EPDM	Ethylene propylene diene	Elastomere moulded diaphragm and seals approvals according to drinking water directive	-10°C to +95°C
Against surcharge			
FKM	Fluorocarbon	Elastomere moulded diaphragm and seals	-10°C to +95°C

■ OPTIONS

Against surcharge	
Pressure gauges 36, 39 or 40	Chapter Accessories
Valve insert SP/HP completely made of stainless steel	Order code: 481 Insert-DN...seal
Valve insert LP completely made of stainless steel	Order code: 481 LP Insert-DN...seal

NOMINAL DIAMETERS, CONNECTIONS, INSTALLATION DIMENSIONS

Series 681: Connection, installation dimensions, ranges of adjustment							
Connection	DN	15	20	25	32	40	50
Inlet DIN EN 10226	G1	1/2"	3/4"	1"	1 1/4"	1 1/2"	2"
Outlet DIN EN 10226	G2	1/2"	3/4"	1"	1 1/4"	1 1/2"	2"
Inlet pressure SP, HP up to	bar	40	40	40	40	40	40
Inlet pressure LP to	bar	25	25	25	25	25	25
Outlet pressure	bar	0,5 - 2	0,5 - 2	0,5 - 2	0,5 - 2	0,5 - 2	0,5 - 2
		1 - 8	1 - 8	1 - 8	1 - 8	1 - 8	1 - 8
		5 - 15	5 - 15	5 - 15	5 - 15	5 - 15	5 - 15
Installation dimensions in mm	L	142	158	180	193	226	252
	l	80	90	100	105	130	140
	l1	85	95	105			
	H (H1)	102 (128 ¹)	102 (128 ¹)	130 (150 ¹)	130 (150 ¹)	165 (185 ¹)	165 (185 ¹)
	h	33	33	45	45	70	70
	SW1	30	37	46	52	65	75
	SW2	28	35	43	48	57	68
Weight	kg	1,2 (1,5 ¹)	1,3 (1,6 ¹)	2,4 (2,9 ¹)	2,6 (3,1 ¹)	5,5 (6,2 ¹)	6,0 (6,7 ¹)
Coefficient of flow K_{vs}	m ³ /h	3	3,5	6,7	7,6	12,5	15

¹for type 681mGFO-LP

²The K_{vs} value was determined according to DIN EN 60534-2-3. Instructions on how to determine size and capacity are to be found under section 2.

MAIN DIMENSIONS, INSTALLATION DIMENSIONS

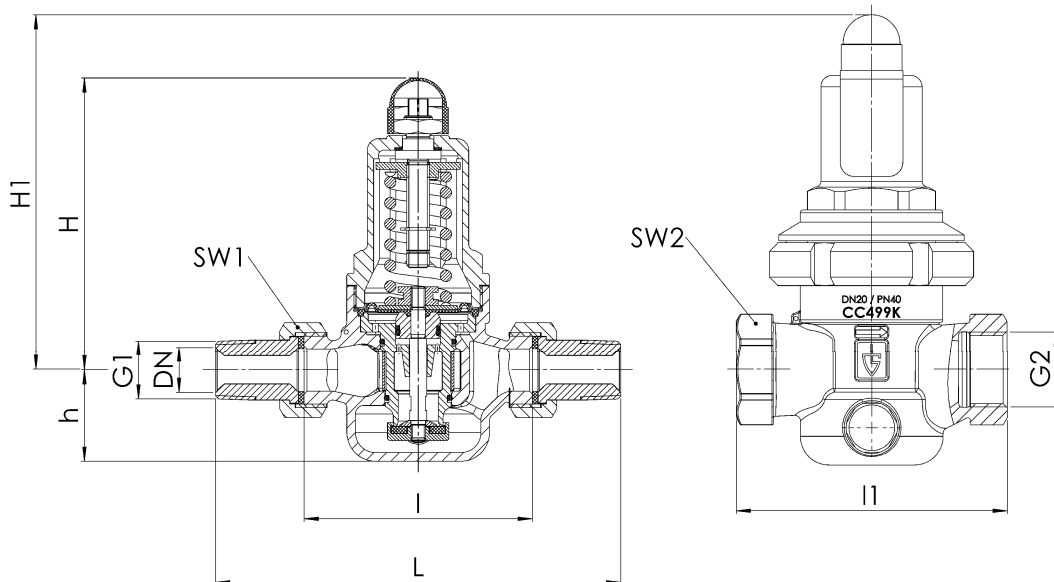

INDIVIDUAL SELECTION / VALVE CONFIGURATION

Series	Valve version	Medium	Lifting device	Outlet pressure	Nominal diameter DN	Connection type		Connection size		Seal	Options	Optional: fixed setting	Quantity
						Inlet	Outlet	Inlet	Outlet				
681	m	GF	0	SP	20	BSP-T m	BSP-T m	20	20	EPDM	Pressure Gauge 36		8
681	m	GF	0	SP	15	f	f	15	15	EPDM			4
681	m	GF	0										
681	m	GF	0										

Dimensioning by pressure loss on the outlet pressure side

Flow chart water

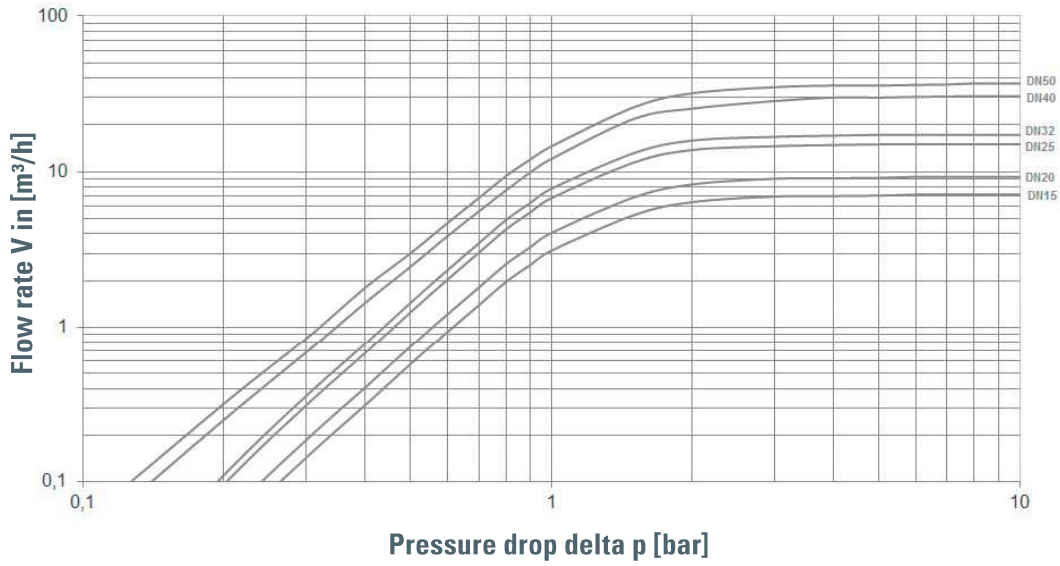

Dimensioning by flow velocity

For liquids:

With help of the chart you can determine the nominal diameter (DN) for a given flow volume V (m³/h). According to DVGW-guidelines (DIN 1988) a flow velocity of 2 m/s in domestic water supply systems should not be exceeded.

For compressed air and other gaseous media:

The usual flow velocity for compressed air is 10 - 20 m/s. For gaseous media the flow volume V should always be shown in actual cubic meters/hour. If the flow volume is given in standard cubic meters, these should be converted into actual cubic meters before using the diagram.

$$V(m^3/h) = \frac{V_{Norm.} (Nm^3/h)}{p_{absolut} (bar)} = \frac{V_{Norm.}}{p_0 + 1}$$

Actual cubic meters are based on the prevailing pressure of the medium on the outlet side of the pressure reducer.

